

**BROKEN TAP REMOVER**

# QUICK SOLUTION TO BROKEN TAP, NO MORE HEADACHE !

Fast, low cost, high performance,  
JOEMARS TR100 BROKEN TAP REMOVER,  
your most reliable partner!



**FEATURES:**

- **Light, small, portable, compact design.**
- **High speed & high efficiency and low cost.**
- **Simple operation, easily remove broken tap.**
- **Full power source choices:**  
100V/110V/120V/200V/220V/230V/240V,  
1 PHASE, 50HZ/60HZ.
- **Dielectric:**  
Using ordinary tap water as machining dielectric liquid.
- **Electrode:**  
Using any brass bar as electrode.
- **Flexibility:**  
Machining easily even on a large workpiece.
- **No damage:**  
Remove taps easily without damage the threads.
- **Complete functions:**  
Auto feed, depth setting (stop at a specific depth), selectable arcing timer, auto retract, workhead swivel alarm messages: depth arrival, arcing, over-temp.
- **More applications:**  
Starting holes for Wire Cut EDM.  
Cutting Tungsten Carbide or any harden steel.

## MACHINING APPLICATIONS:

### SMALL WORKPIECE

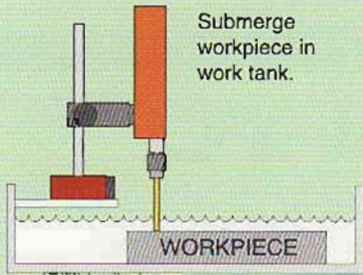

### LARGE WORKPIECE

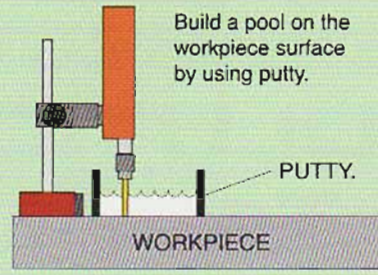

### NON-VERTICAL MACHINING

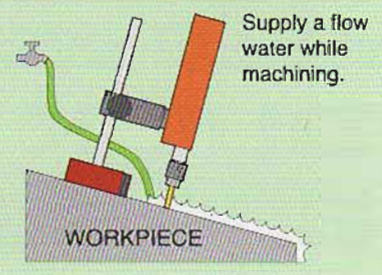

## HOW TO REMOVE BROKEN TAP:

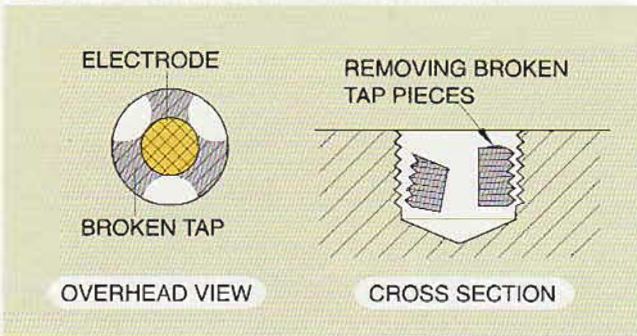

## WORKHEAD SWIVEL:

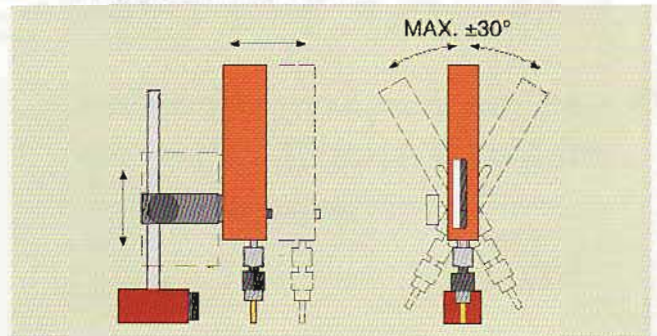

## SPECIFICATIONS:

### GENERATOR:

Weight: 17Kgs

Dimensions: 290X345X285 mm

### MACHINE UNIT:

Weight: 6Kgs with magnetic stand

Dimensions: 53X70X375 mm

Electrode Holder : Max.  $\varnothing 6.5$  mm

\* All specifications & design are subject to change without notices.

## DIMENSIONS:

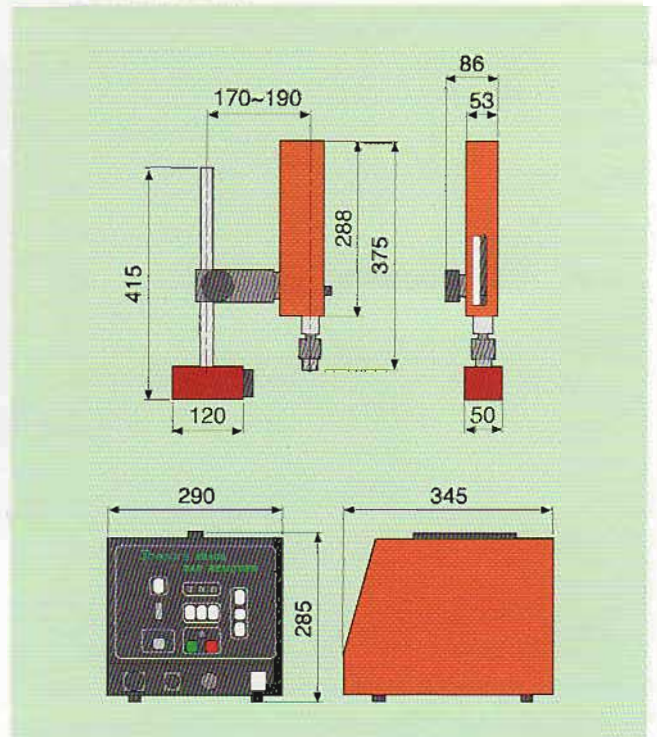

## STANDARD ACCESSORIES:

- |                  |                            |
|------------------|----------------------------|
| 1. Generator     | 5. Brass electrode bar     |
| 2. Machine unit  | $\varnothing 1.5$ mm x4PCS |
| 3. Chemical clay | $\varnothing 2.0$ mm x2PCS |
| 4. Chuck handle  | $\varnothing 2.5$ mm x2PCS |
|                  | $\varnothing 3.0$ mm x2PCS |
|                  | $\varnothing 4.0$ mm x1PC  |
|                  | $\varnothing 5.0$ mm x1PC  |
|                  | $\varnothing 6.0$ mm x1PC  |



## JOEMARS MACHINERY & ELECTRIC INDUSTRIAL CO., LTD.

No. 66, Lane124, Sec. 1, Youyuan Road, Tatu Hsiang, Taichung Hsien, Taiwan 432

Tel: 886-4-2691-7566 Fax: 886-4-2691-7555

<http://www.joemars.com.tw> E-mail : [joemars@ms11.hinet.net](mailto:joemars@ms11.hinet.net)